

# **ASD 1200 MD TA32**

**Technical documentation**

Date of issue: 02/2013



# **ULT 1200**

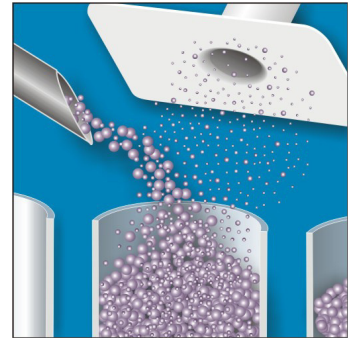

**Clean air,  
high performance.**

**ASD-series, mobile  
air extraction and  
filtration units for  
dust and smoke.**



**Air handling equipment for environmental and health protection**

# Technical documentation

## Air extraction and filtration unit

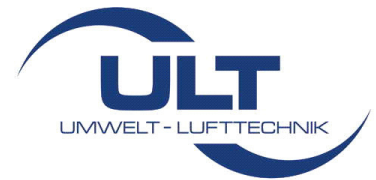

# ASD 1200 MD TA32

### Use and application

The **ASD 1200 MD TA32** is suitable for collecting and filtering dry and non-combustible types of **dust, gases and fumes** contained in non-explosive air mixtures. Any emitted and partially unhealthy **pollutants** ought to be extracted by collecting elements directly at their place of origin and filtered by the ASD 1200 MD TA32. The material of the filter elements ensures effective filtering out of the various dust particle sizes. The combination of the pocket filter with the activated charcoal layer guarantees a particle separation efficiency of > 99 % and the extraction of unhealthy gases and fumes from the polluted air. The different filter elements can be changed separately extending the lifetime of the main filter element.

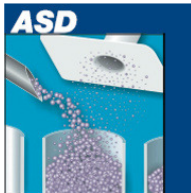

smoke and dust

### Examples

- ⇒ engraving
- ⇒ polishing
- ⇒ abrading

### ULT 1200 modular air extraction and filtration unit

mobile unit,  
with storage filter system  
robust steel housing, powder coated  
RAL 7035 light grey / RAL 7001 silver-grey



### Filter system:

Storage filter system  
Filters which are replaced once they are saturated.

### Filter technology:

Main filter module

- (1) Pocket filter F7  
filter class: F7 fine dust filter according to DIN EN 779
- (2) Adsorption filter cassette A16  
filter medium: activated charcoal (16 kg)
- (3) Adsorption filter cassette A16  
filter medium: activated charcoal (16 kg)

# Technical documentation

## Air extraction and filtration unit

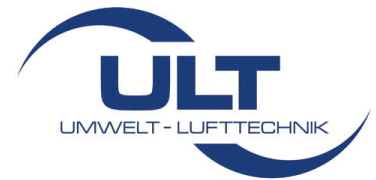

# ASD 1200 MD TA32

## ASD 1200.0-MD.bb.cc.5001

Parameter	unit	-MD.18.10.	-MD.45.13.	-MD.47.13.	-MD.81.13.
Max. air flow	m³/h	1.500	1.700	2.100	1.660
Max. vacuum	Pa	3.250	2.600	2.880	2.400
Nominal capacity	m³/h / Pa	1.000 / 1.700	1.000 / 1.800	1.000 / 2.500	1.000 / 1.800
Motor-nominal power	kW	0,86	1,50	2,20	1,50
Nominal voltage	V	1~ 230	3~ 400	3~ 400	1~ 230
Nominal current	A	4,8	3,5	4,8	8,75
Frequency	Hz	50 / 60	50	50	50
Protection class	IP	54	54	54	54
Type blower		blower	ventilator	ventilator	ventilator
Noise level (at 50 - 100%)	dB(A)	60	62	62	72
Air flow controller		yes	no	no	no
Loaded particle filter indicator	optical	yes	yes	yes	yes
Operating hours counter		no	yes	yes	yes
SUB D9 interface	(1*)	optional	optional	optional	optional
Digital control integrated	(2*)	optional	no	no	no
Remote digital control		optional	no	no	no
Air outlet DN 200	(3*)	optional	optional	optional	optional
Air intake options		1x Ø 150 mm take off			
	position	backside of the unit			
		1x Ø 160 mm take off			
Air outlet		air exhaust louver			
	position	lower rear side			
Width	mm	790			
Depth	mm	820			
Height	mm	1.340			
Weight	kgs	ca. 180			
Length of power cable	m	5			
<b>Filter system</b>		filter system: storage filter			
		filter set consisting of:			
	(1)	Pocket filter F7			ULT 02.0.612
	(2)	Adsorption filter cassette A16			ULT 02.1.606
(3)	Adsorption filter cassette A16			ULT 02.1.606	
Spark protection (expanded metal filter)		<b>optional</b>			ULT 02.0.676

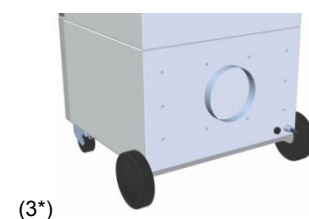
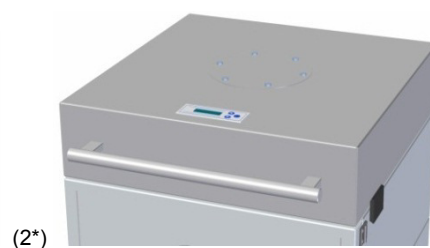
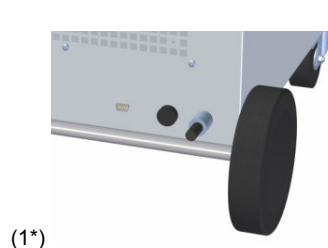

# ASD 1200 MD TA32

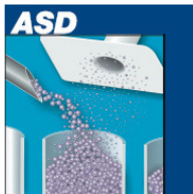

smoke and dust

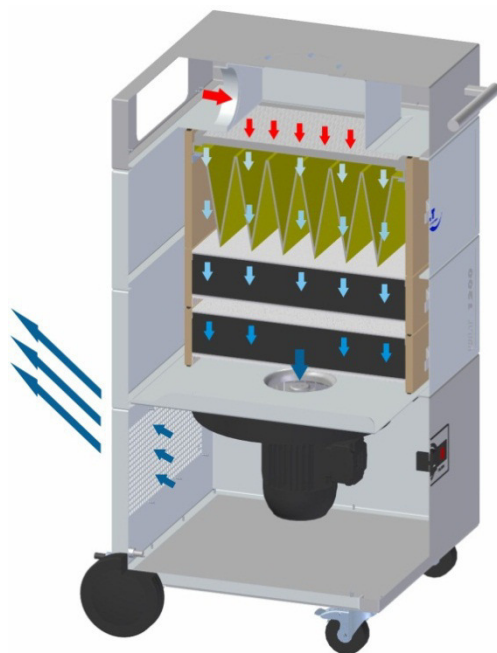

- ← raw gas
- ← filtration
- ← clean gas

### Functional principle:

At the **clean-air side** of the filter, a vacuum generator with a high pressure reserve produces a volume flow matched to the respective application. This volume flow can be individually and infinitely variably regulated by some units. Thus, the polluted air will be reliably extracted.

The **particles** are separated and held back at the first filtration level in the pocket filter. **Gaseous and vaporous air pollutants** are separated (adsorbed) in an activated charcoal filter.

The filtering effect of activated charcoal is based on adsorption, i. e. an accumulation of substances (to be filtered out) on the surface of the activated charcoal. During this process there are no chemical reactions and changes of the captured substances. The construction of the filter elements underlies the air volume of the unit; the contact time is based on a medium adsorption reaction.

Storage filter system

Filters which are replaced once they are saturated.

Filtration set complete:

- |                             |  |
|-----------------------------|--|
| (1) <b>fine dust filter</b> | Pocket filter F7   |
| (2) <b>gas filtration</b>   | Adsorption filter cassette A16<br>(16 kg activated charcoal) |
| (3) <b>gas filtration</b>   | Adsorption filter cassette A16<br>(16 kg activated charcoal) |

This excellent filter efficiency makes it possible to recirculate the **filtered air** and reduce energy costs.

### Optional filter elements:

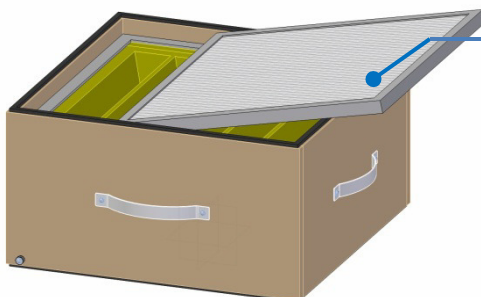

Spark protection:  
Expanded metal filter ULT 02.0.676

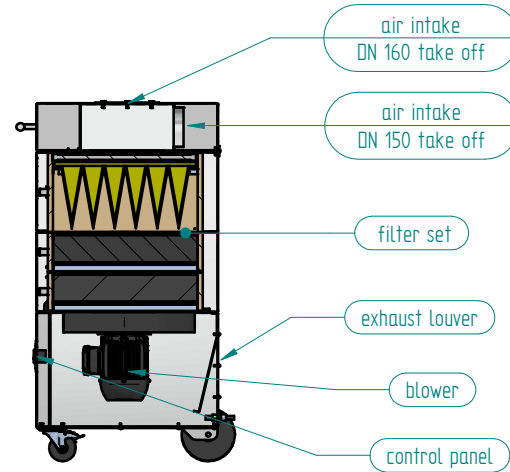
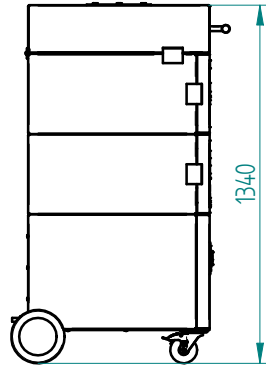
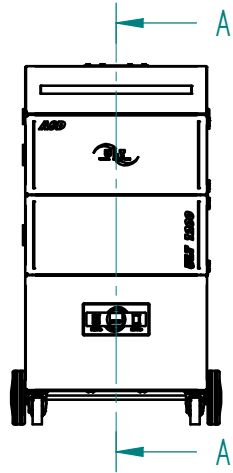

cutaway A-A

filter set consisting of:

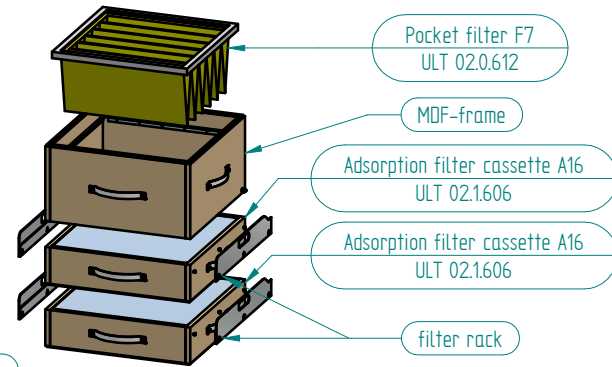
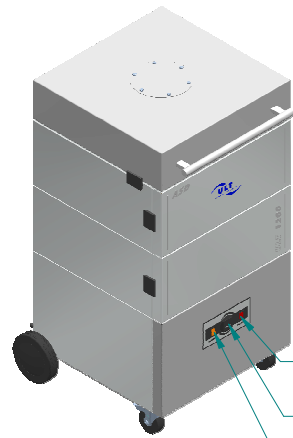
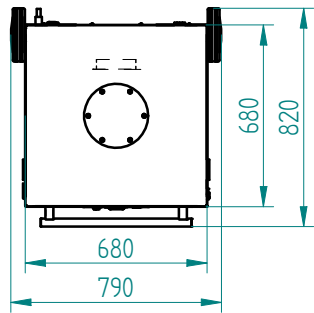

Weitere Maße sind dem 3D-Datensatz zu entnehmen. Für die Zeichnung behalten wir uns alle Rechte vor.  
Other measure are to be taken from the 3D record. For the drawing we reserve ourselves all rights.



				ULT AG Am Gopelreich 1 D-02708 Lobau		designation ASD 1200 MD TA32	
				2013	date	drawing number:	
				14.02.	JSACZ	name JSACZ	
				edit.	14.02.	drawing number: ULT 1200_00_110_001	
				verf.	JSACZ	scale: 1 : 20	
issue	revision	day	name	Norm			